

REINHOLD ENVIRONMENTAL Ltd.



2011 APC Round Table & Expo Presentation

July 11-12, 2011, in Cleveland, OH / Hosted by FirstEnergy

All presentations posted on this website are copyrighted by Reinhold Environmental, Ltd (RE). Any unauthorized downloading, attempts to modify or to incorporate into other presentations, link to other websites, or obtain copies for any other uses than the training of attendees to RE's Conferences is expressly prohibited, unless approved in writing by RE or the original presenter. RE does not assume any liability for the accuracy or contents of any materials contained in this library which were presented and/or created by persons who were not employees of RE.



***Options for Upgrading an Existing ESP
with Fabric Filter Technology***

2011 APC Roundtable

Phil Roberts

Trends for PM Control

- **Regulations are becoming more stringent**
 - **Proposed UMACT 0.030 lb/MMBtu Total PM**
 - **Continuous PM Monitors – located in stack, not after PM device**
 - **30 day rolling average including startup & shutdown**
- **Fuel sources are typically not fixed**
- **Sorbents may be required for HAP control**

Methods Of Particulate Matter Control

Mechanical

- **Filtration (Baghouse)**
- **Cyclone***
- **Venturi Scrubber***
- **Impingement***

Electrical (Electrostatic) Precipitation

*** *Less effective on sub-micron particulates***

Electrostatic Precipitators

Implications of Sorbent Injection with Dry ESPs

Sodium based sorbent for HCl, SO_x control

- Decrease flyash resistivity
- Increase ESP Performance / Decrease PM emissions

Lime for HCl, SO_x Control

- Increase resistivity
- Decrease ESP Performance / Increase PM Emissions

PAC for Hg control

- Most likely will increase PM emissions
- Flyash sales will be impacted

Sorbent Consumption

- Utilization lower than fabric filter

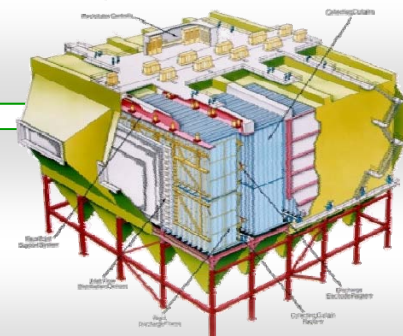

Dry ESP

- **Final PM Filter**
- **Size dependent on:**
 - **Emission**
 - **Fuel / Ash**
 - **Gas Flow**
 - **Gas Composition**
 - **Gas Temperature**
- **Excellent turndown**
- **Low maintenance**
- **High power consumption**
- **Poor performance with some sorbents**

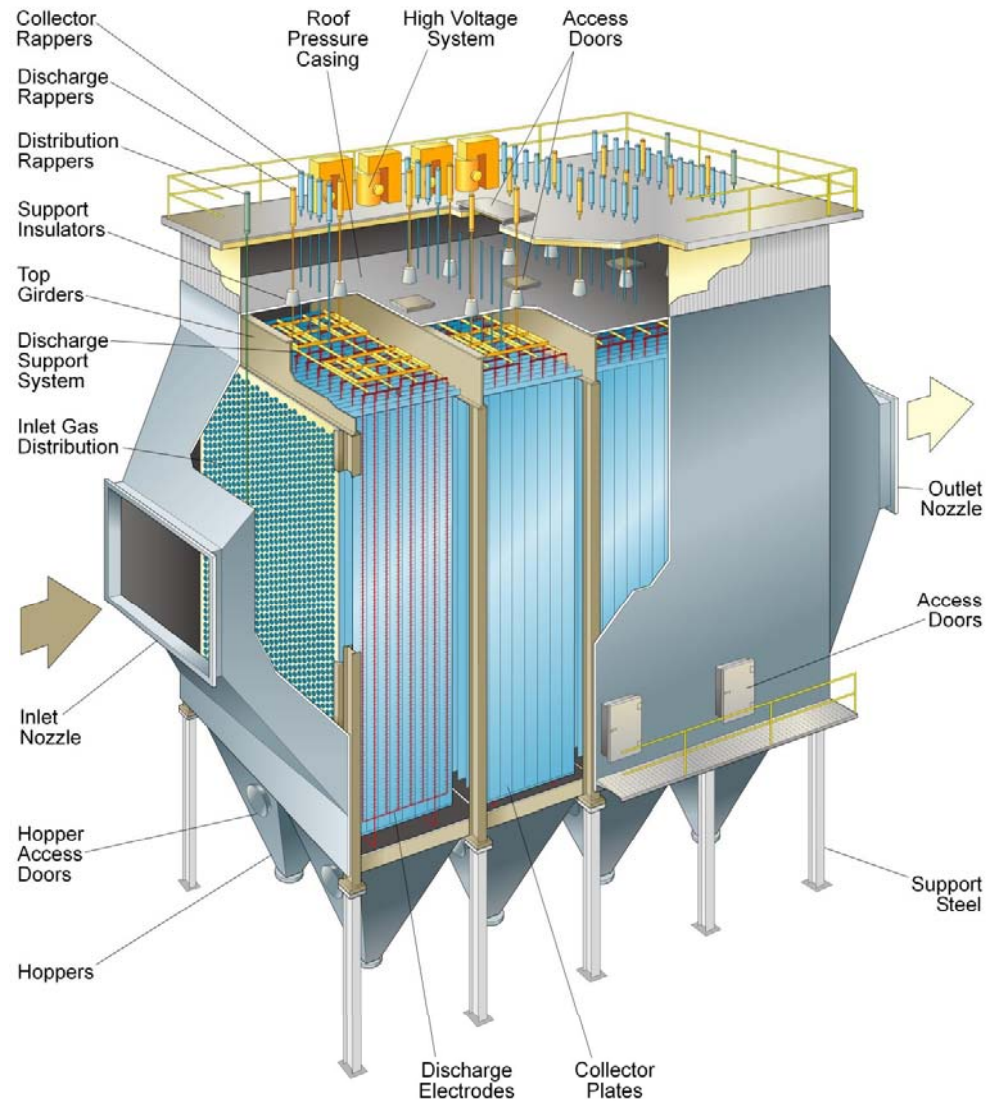

Fabric Filtration

History of Fabric Filtration

<i>Late 1800s</i>	Reverse air baghouses were being used for metallurgical applications. Bags were made of wool and cotton.
<i>By 1920</i>	Electrostatic precipitators developed and became dominate device particulate collection.
<i>1939</i>	Nylon bags were developed. By 1950, synthetics dominated the bag materials
<i>1960s and 1970s</i>	Pulse jet units were developed and were used on small and medium sized units. Reverse air dominated utility size baghouses.
<i>1990s</i>	Australia and South Africa led the way for pulse jet baghouses for utilities.

Use of Fabric Filters for US Utilities

- **Regulations are becoming more stringent**
 - **Proposed UMACT 0.030 lb/MMBtu Total PM**
 - **ESP size is dependent on emission, flyash composition, flue gas composition and gas temperature**
 - **Fabric filter size is dependent on gas flow**
 - **Bag material selection is dependent on temperature**
- **Variable fuel sources**
 - **ESP emissions are sensitive to fuel**
 - **Fabric filter emissions are not sensitive to fuel**
- **Total US coal fired capacity \approx 330,000 MW**
 - **Reverse Air \approx 25,000 MW since 1970s**
 - **Pulse Jet \approx 40,000 MW since 1990s**

US Utility Fabric Filter Trends

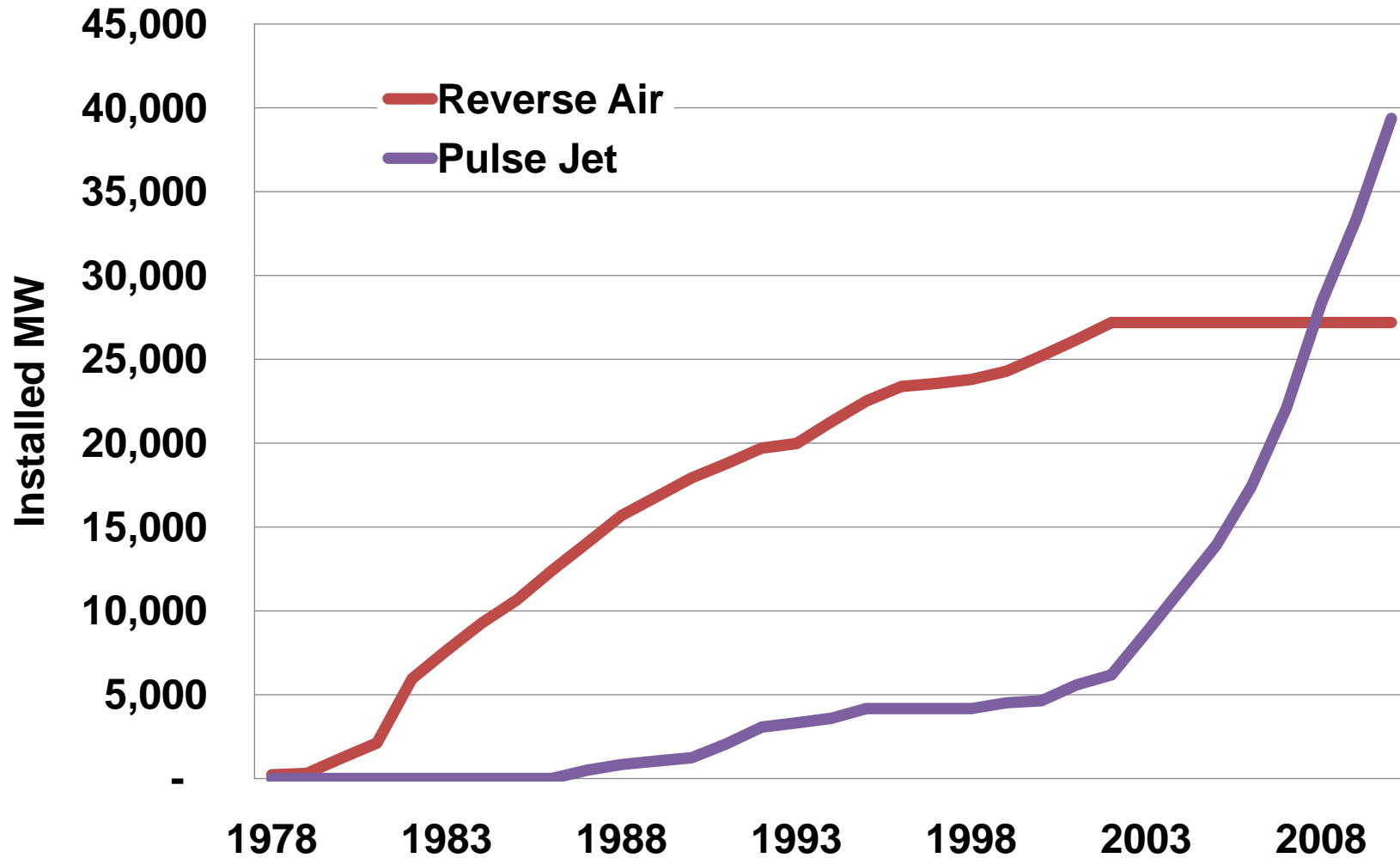

Barrier Filtration

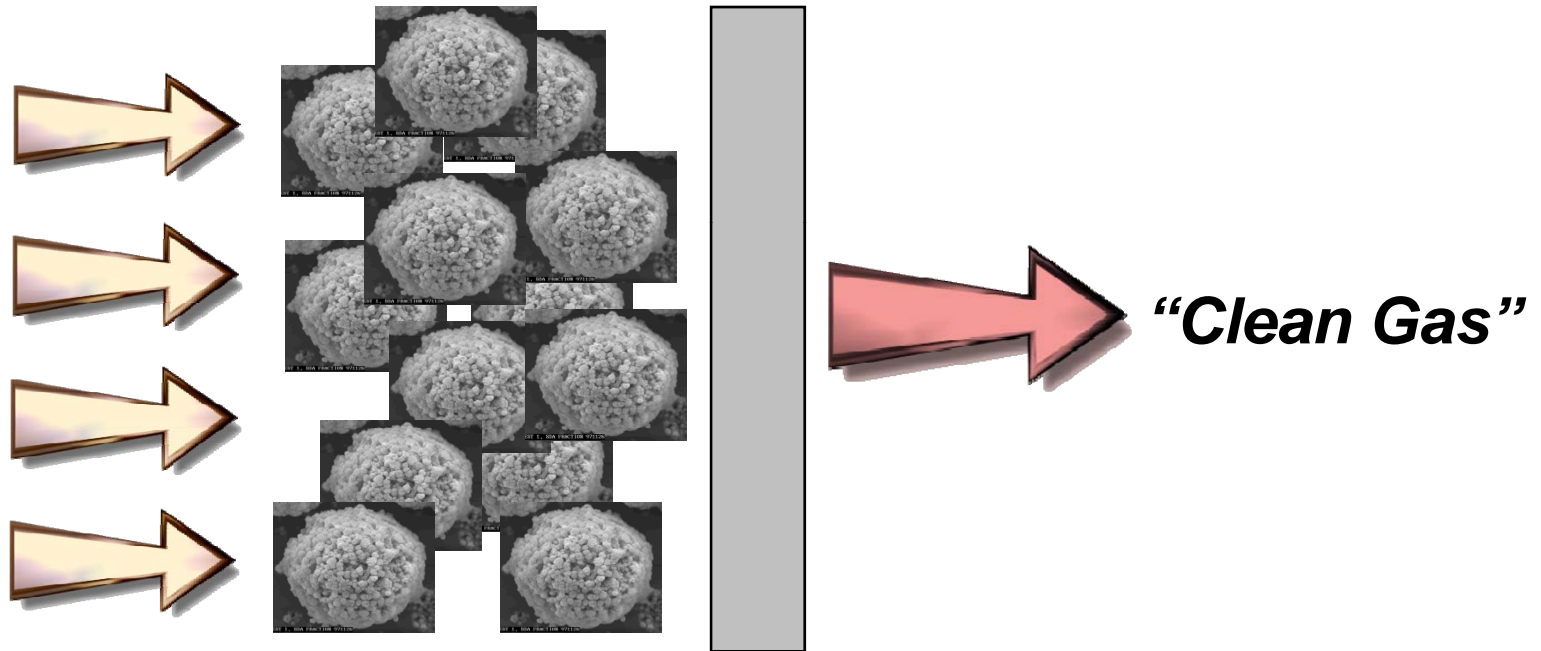

Gaseous Absorption with Sorbents

Sorbents and flyash build up on filter bag surfaces forming reactive bed of particles:

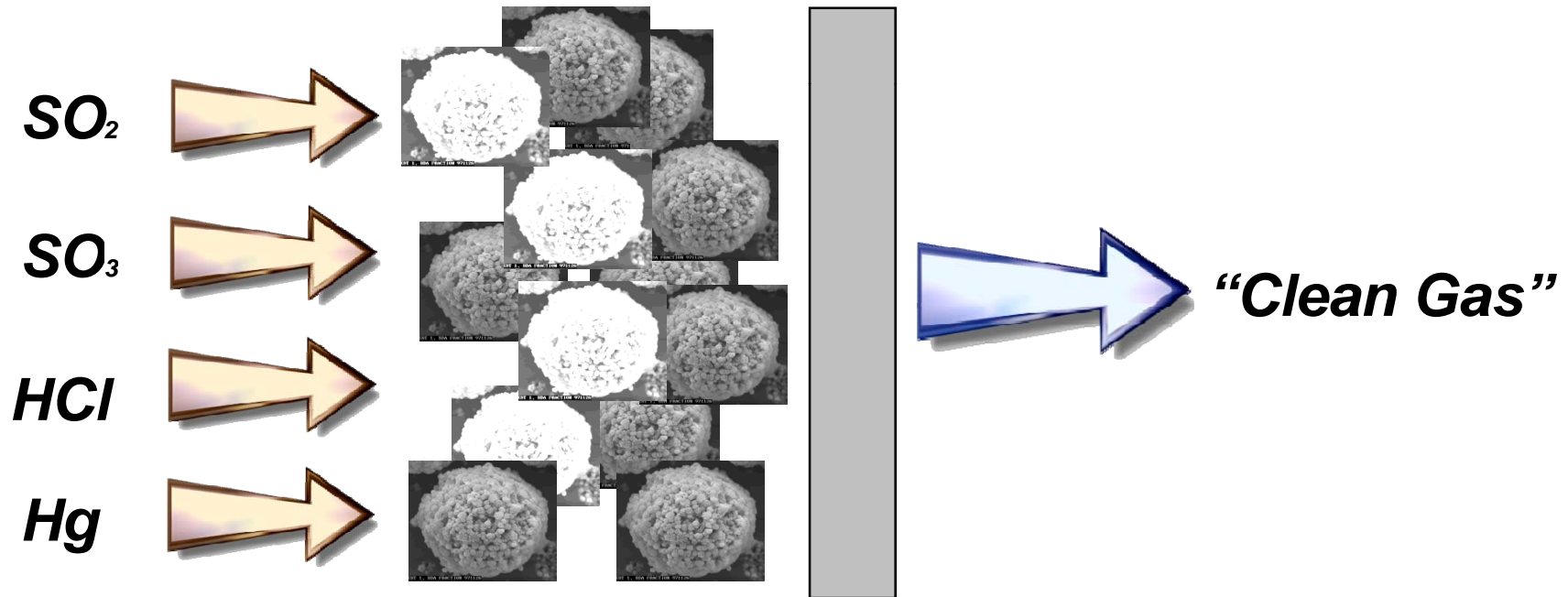

Implications of Sorbent Injection with Fabric Filters

Performance (emission) is not sensitive to sorbent

Higher S fuels possible with alkali sorbent

- **SO₃ reduction**

Higher sorbent utilization than ESP

- **Acts as fixed bed filter**
- **May not work as well with membrane bags**
- **PAC (Flyash sales may be impacted)**

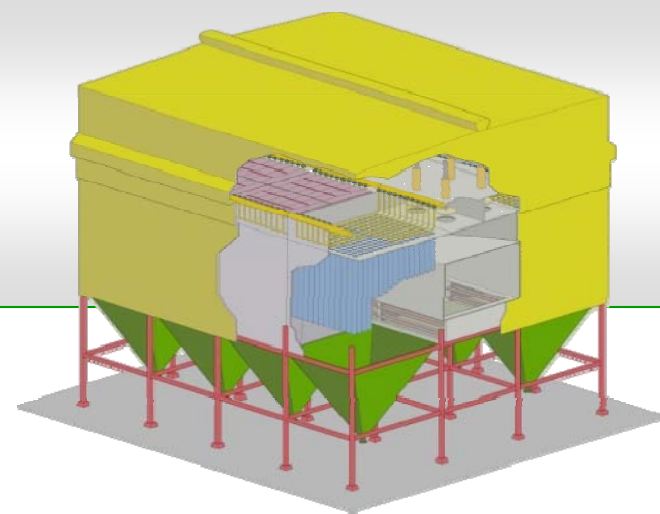

Pulse Jet Fabric Filter

- Final PM Filter
- Size dependent on:
 - Gas flow
- Excellent turndown
- Medium maintenance
- High pressure loss
- Good performance with sorbents

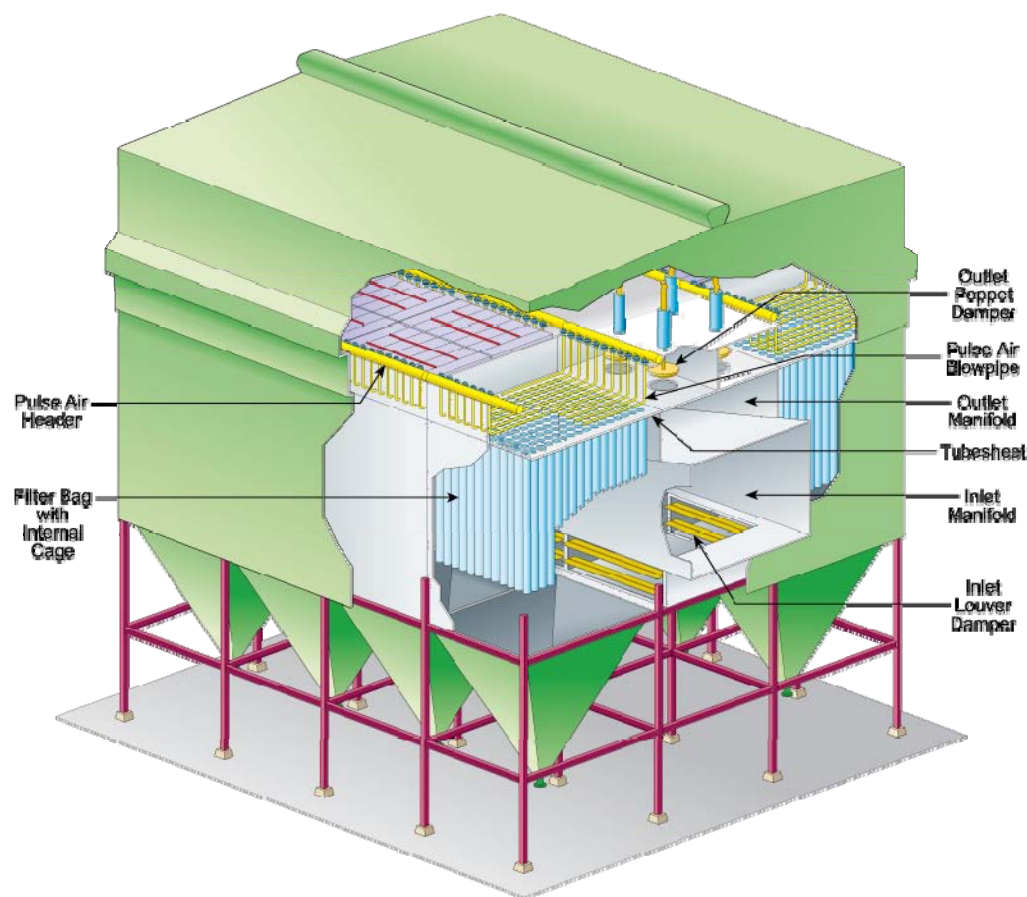

Possible Options for ESP's to Meet MACT:

- **ESP upgrades**
- **ESP + new FF (Toxicon)**
- **Conversion of ESP to FF**
- **Replace with New FF**

Data Required for Decision Making

- **GA's for existing APC equipment & ductwork**
- **Process data (gas flow, temperature, dust load, fuel characteristics, ash characteristics)**
- **ID fan manufacturer/model/performance curve**
- **PM emissions goal, SO₂ emissions goal, Hg emissions goal. Must baseline current emissions – filterable & condensables.**
- **Will a DSI system be required, and type reagent used?**
- **Does the plant currently sell flyash?**
- **Outage timing & duration**

PJFF in Polishing Application (COHPAC™ or TOXECON™)

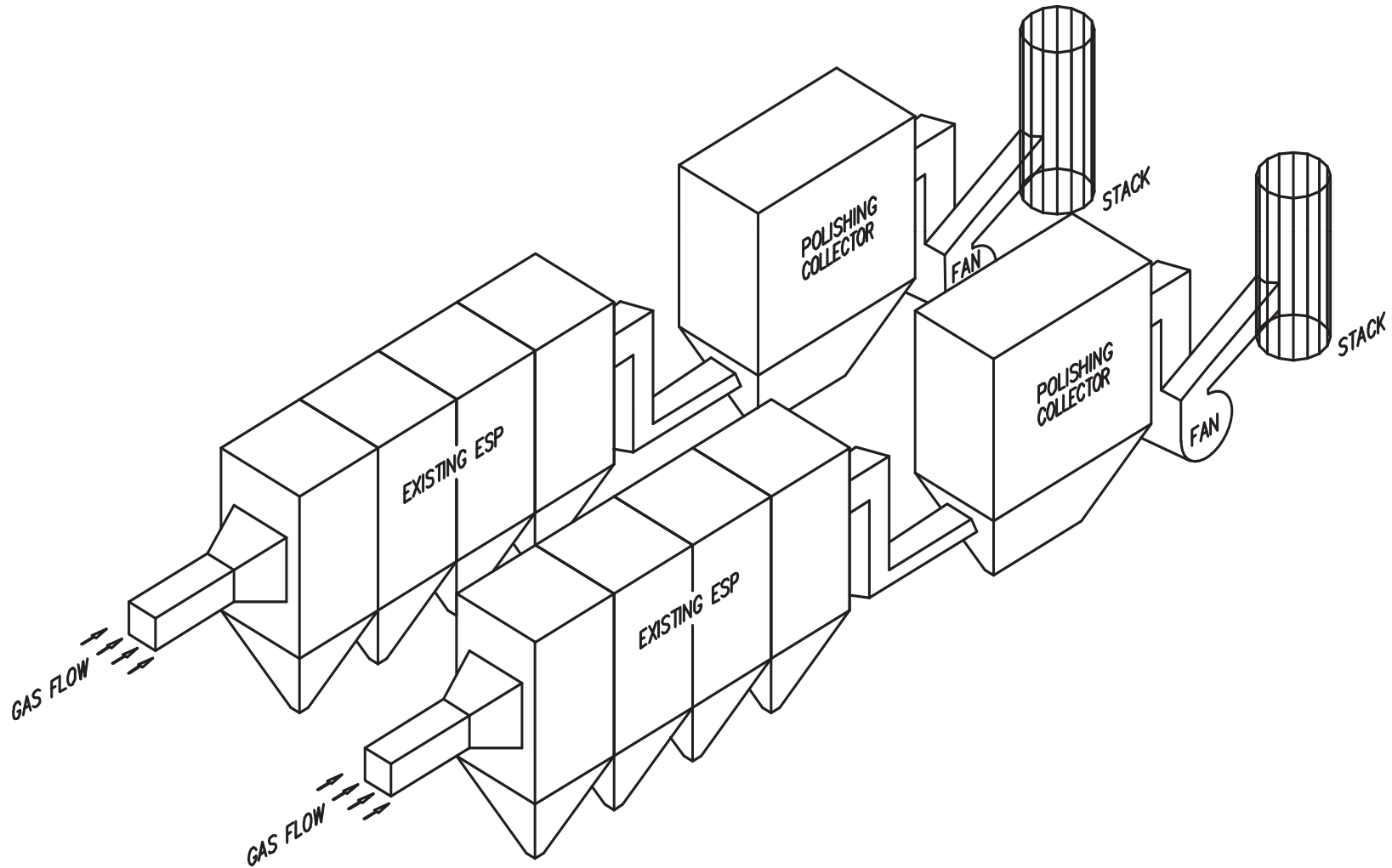

PJFF - Slipstream Application

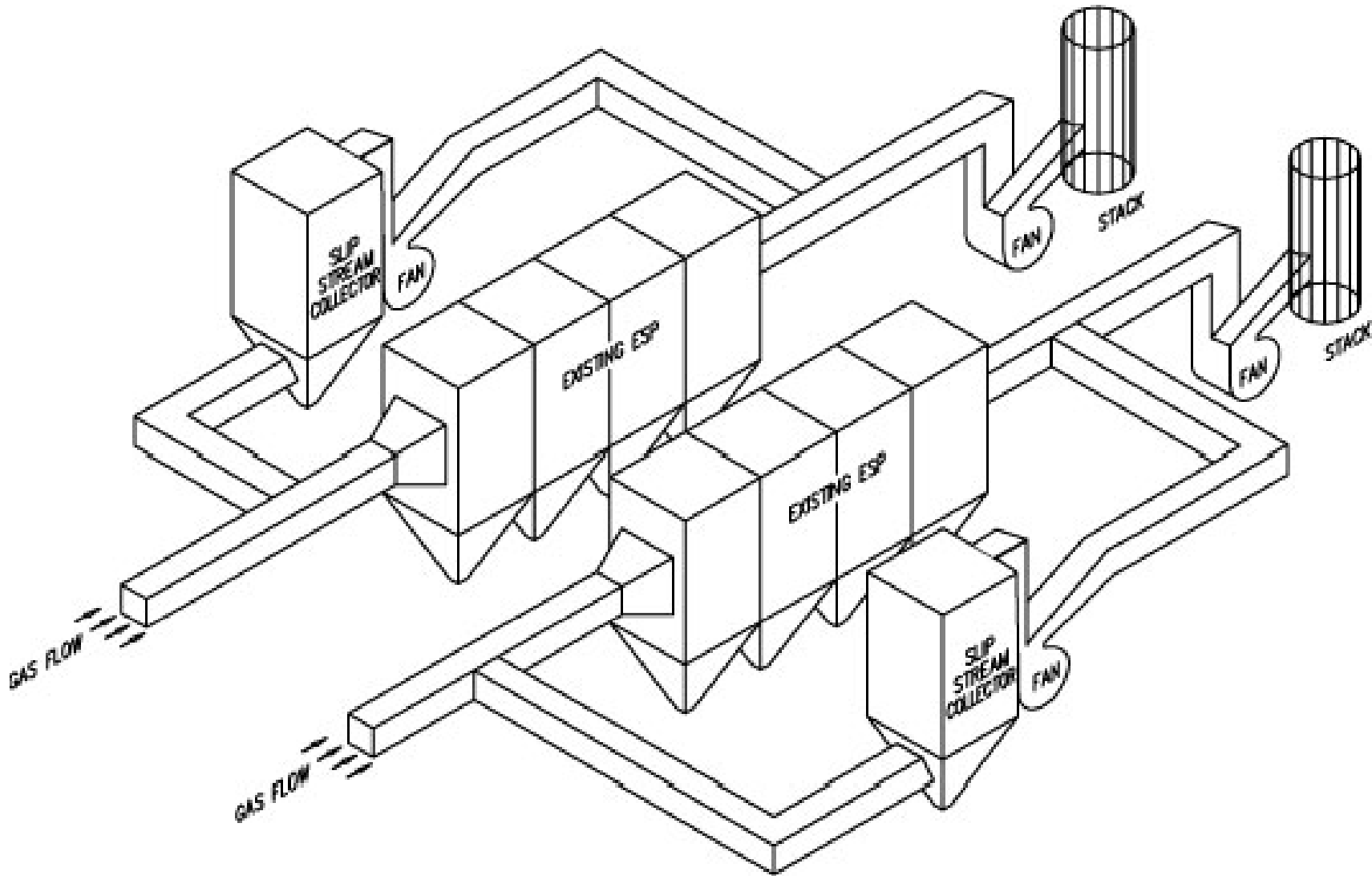

ESP to Pulse Jet Conversion

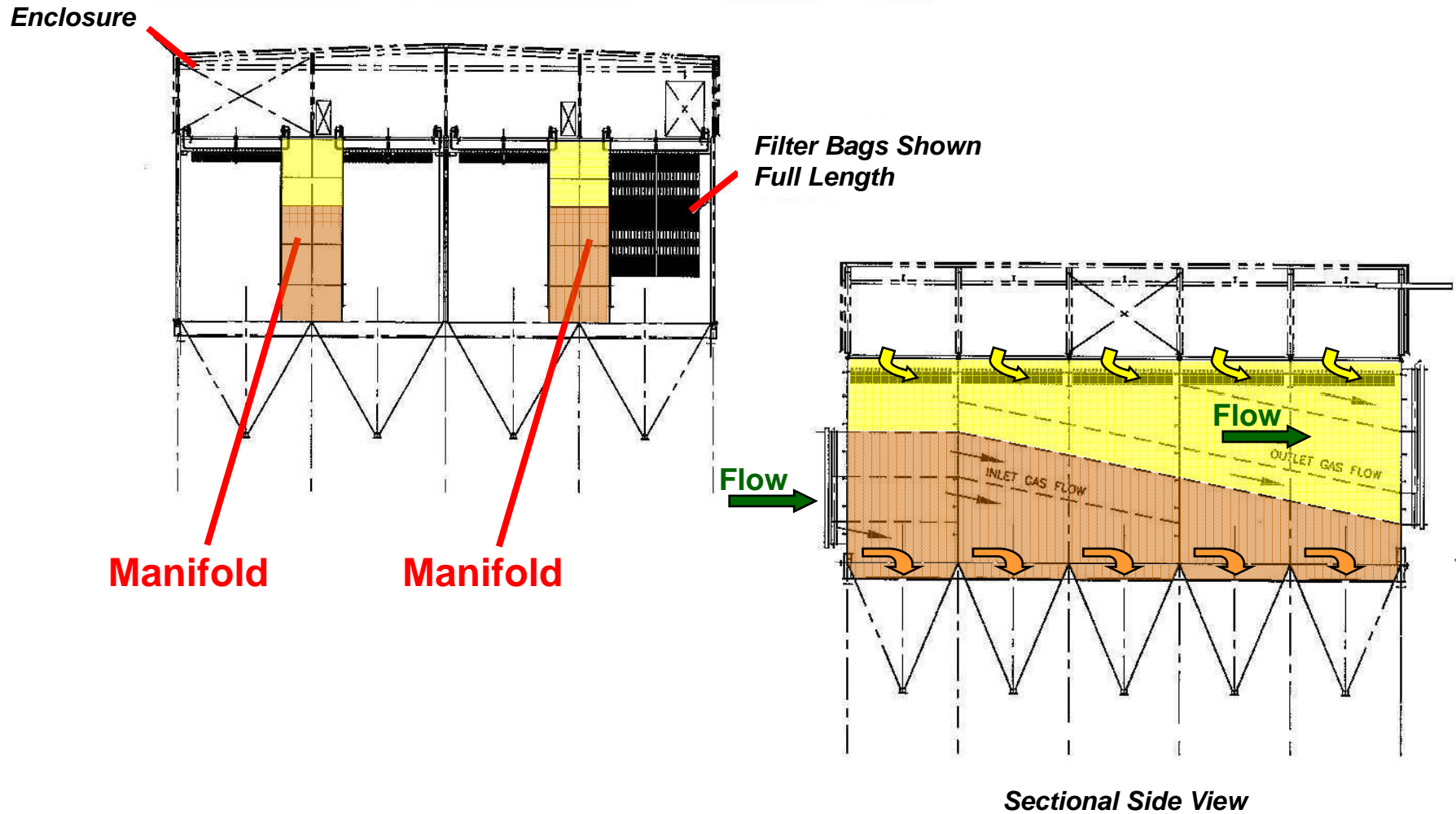

Summary - Key Issues

- **Unit tie-in - outage**
- **Sale of Ash and disposal costs**
- **Maintenance costs**
- **Capital cost (key factor is arrangement)**
- **Operating cost (sorbent & PAC costs, power cost)**

Cost Study Required

Phase 1

**Perform an Engineering Study
of the 3 options - budget level**

Phase 2

**Depending upon the results of phase 1
it may be necessary to complete a
more detailed analysis of the top 2.**

Example Case Study

The following figure depicts the plant arrangement:

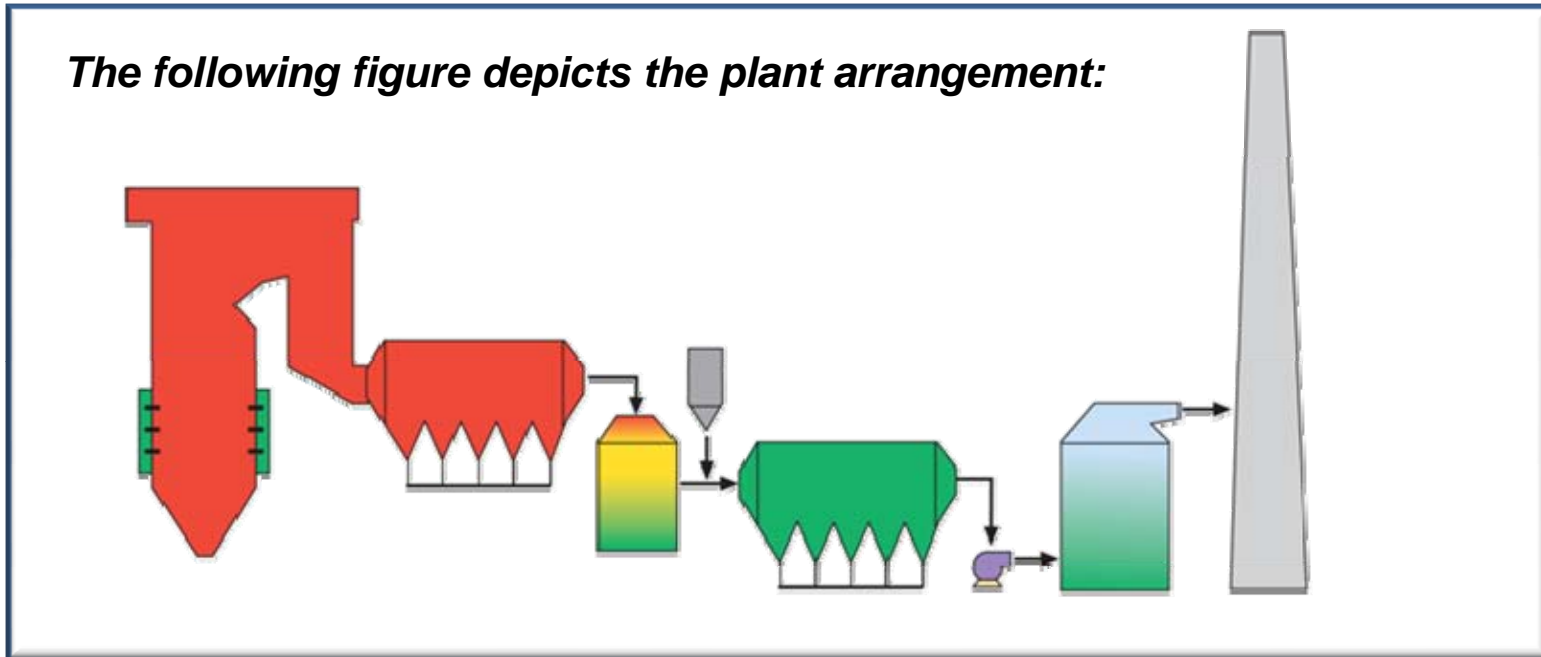

Schematically, the scenarios included in this evaluation are indicated below:

Base Size:

PC Boiler → Economizer → **ESP Deenergized** → **Air Heater Modified** → **PJFF** → **Upgraded Fan** → FGD → Stack

High and Ultrahigh Ratio Sizes:

PC Boiler → Economizer → ESP → Air Heater → **PJFF** → **Upgraded Fan** → FGD → Stack

Example 1 - Case Study

NPV 350 MW Unit			
	Base (4 ft/min)	High Velocity (6 ft/min)	Ultrahigh Velocity (8 ft/min)
Baghouse air-cloth-ratio			
Sales of Ash from ESP	-	-	-
Ash Disposal	-	-	-
Net Power Cost Savings ESP not in service	(7,294)	-	-
ESP maintenance savings	(2,382)	-	-
PAC cost (CONSTANT FOR ALL SIZES)	-	-	-
PJFF maintenance	12,197	13,800	34,533
Total Operating & Maintenance Cost	2,521	13,800	34,533
Initial Material & Labor PJFF & PAC system with flues	29,618	25,070	24,644
Total Cost for 20 year operation	32,139	38,870	59,177

Example 2 - Case Study

NPV 550 MW Unit			
Baghouse air-to-cloth ratio	Base (4 ft/min)	High Velocity (6 ft/min)	Ultrahigh Velocity (8 ft/min)
Sales of Ash from ESP	-	-	-
Ash Disposal	-	-	-
Net Power Cost Savings ESP not in service	(26,957)	-	-
ESP maintenance savings	(1,799)	-	-
PAC cost (CONSTANT FOR ALL SIZES)	-	-	-
PJFF maintenance	20,347	20,195	46,043
Total Operating & Maintenance Cost	(8,409)	20,195	46,043
Initial Material & Labor PJFF & PAC system with flues	36,160	27,973	27,011
Total Cost for 20 year operation	27,751	48,168	73,054

